

A large industrial stainless steel machine with a hopper at the top and a conveyor belt at the bottom. A blue diagonal banner is overlaid on the top left. A small orange rounder is shown in a circular inset on the right. The machine has a central panel with horizontal slats and two emergency stop buttons.

SVP

AUTOMATIC VOLUMETRIC
DIVIDER ROUNDER



CSC SARTORI



OVER
250
TYPES OF BREAD

SVP2/SVP3 fully automatic and compact. While processing you can adjust speed and weight without stopping production.

SVP2/SVP3 completamente automatica e compatta. Durante il ciclo produttivo si può regolare la velocità e peso senza interrompere il ciclo di produttivo.

2 • **3**
ROWS ROWS



TOUCH CONTROL PANEL

Touch-screen panel with possibility of 200 storable recipes and synchronising with other machines.

Pannello con possibilità di memorizzare fino a 200 ricette e sincronizzare altre macchine.



ELECTROMECHANICAL PANEL

Facile da utilizzare ed intuitivo con 7 opzioni di regolazione.

User-friendly and intuitive with 7 adjustment options.

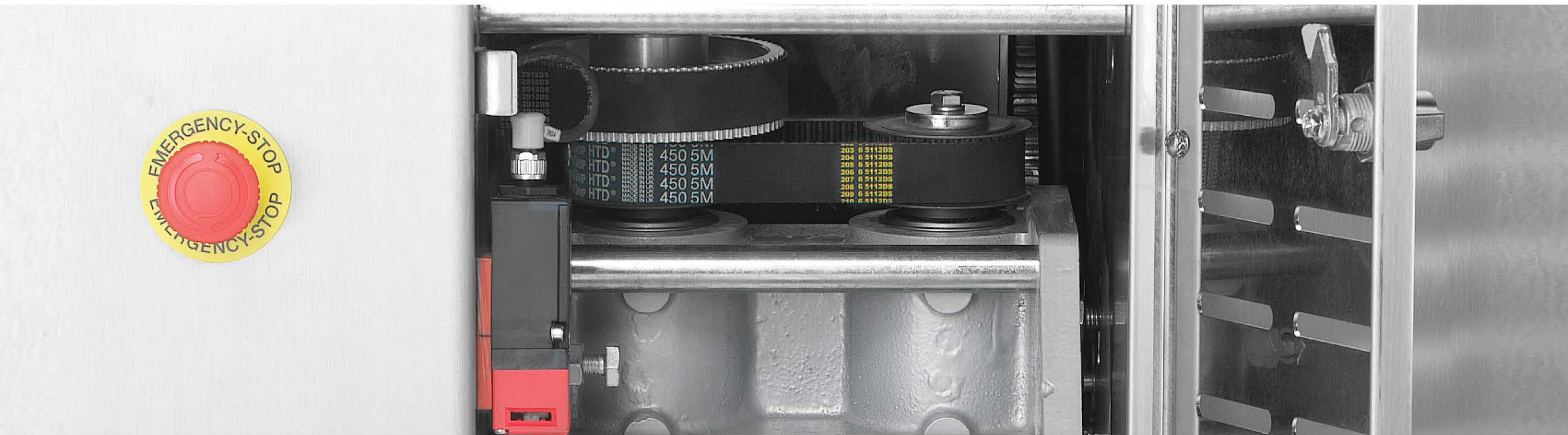

TECHNICAL SPECIFICATIONS

MACHINE MODEL SVP

DIMENSIONS	cm	165 x 80 x 183 h
EXIT BELT LENGTH*	cm	42 - 75 - 109
NET WEIGHT	kg	530
PACKING DIMENSIONS	cm	120 x 80 x 185 h
PACKING WEIGHT in CRATE	kg	650
INSTALLED POWER	kW	1,8

*Other length and versions available on request

2 ROWS max 3000 pcs/h

SVP2-SA	
gr min.	gr max.
20	60
35	100
40	130
100	200
150	280

SVP2-DA	
gr min.	gr max.
20	110
30	150
40	200
80	280

3 ROWS max 4500 pcs/h

SVP3-SA	
gr min.	gr max.
20	60
35	100
40	130

SVP3-DA	
gr min.	gr max.
20	110
30	130

** The weight range in grams depends on hexagons dimensions in use. The indicated weight dough ranges are the effective potential machine output . All data are not binding. CSC SARTORI TRADE srl reserves the right to effect changes as necessary without notification.



Min.

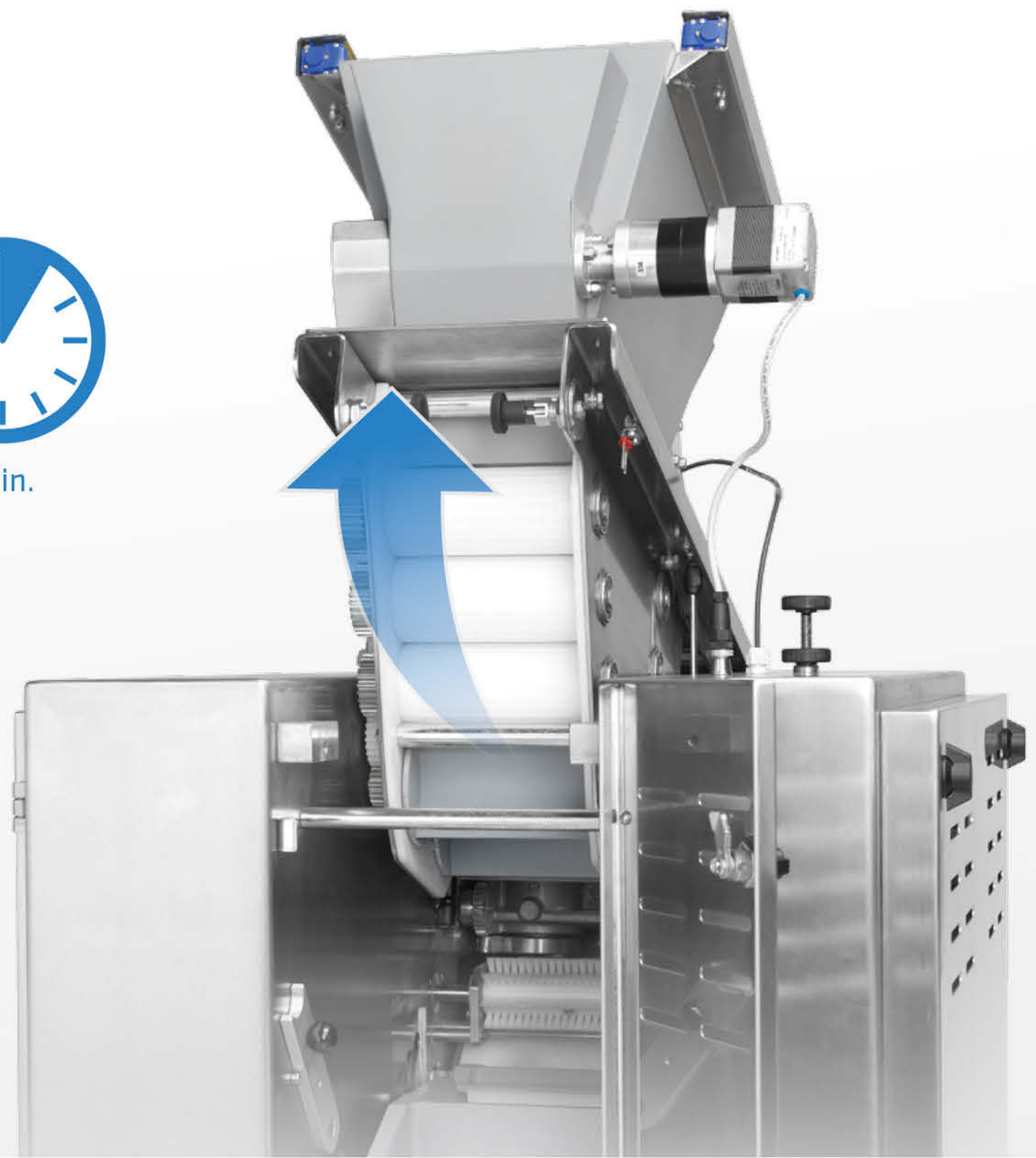

FAST CLEANING

Designed to be cleaned in all its parts quickly and optimally.

Studiata per essere pulita in tutte le sue parti in modo veloce ed ottimale.

TYPES OF BREAD

Machine matched for different types of breads.

Macchina adatta alla produzione di vari tipi di pane.

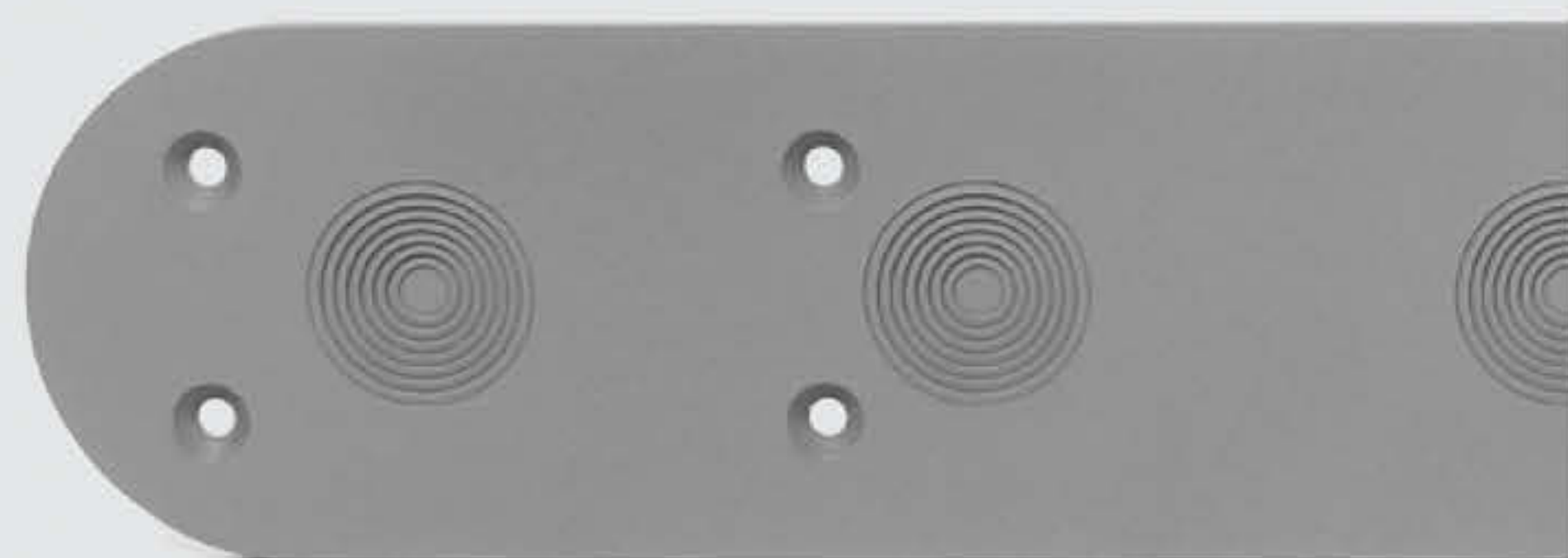

EASY ROUNDING

High working range with only "two click" without removing any mechanical parts.

Con "2 click" si ottiene un alto range di lavoro, senza la necessità di rimuovere nessuna parte meccanica.



MORE FLOUR

Internal and external flour dusters system allowing the operation without using oil in contact with dough.

Sistema di sfarinatori interni ed esterni che permettono il funzionamento senza utilizzo di olio a contatto con l'impasto.



ANTI-STRESS

Innovative system to stress the least possible the dough in order to get an optimal dough processing.

Sistema innovativo per stressare il meno possibile la pasta, per una lavorazione ottimale dell'impasto.

FEEDING

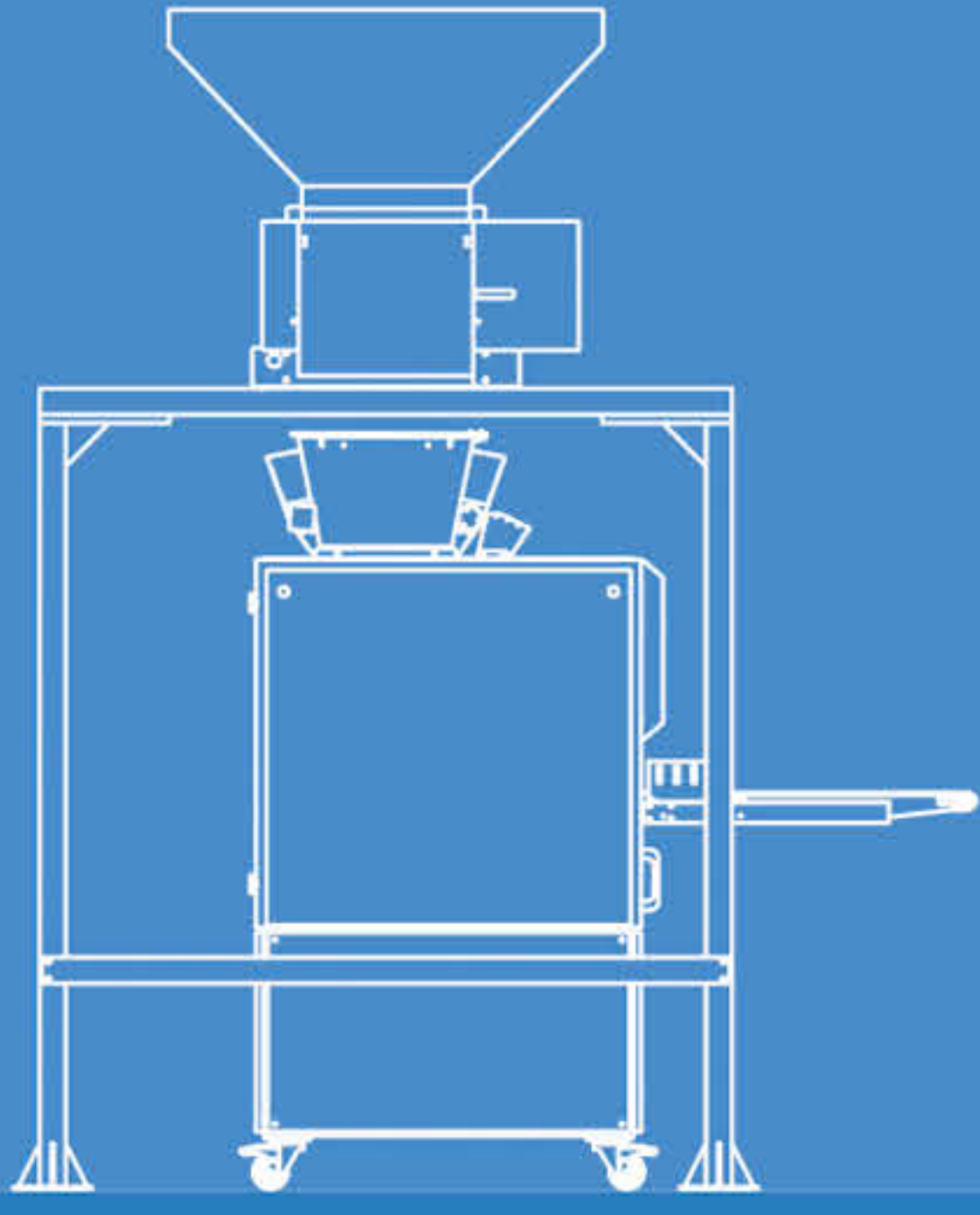

CSC  SARTORI

PROOFING

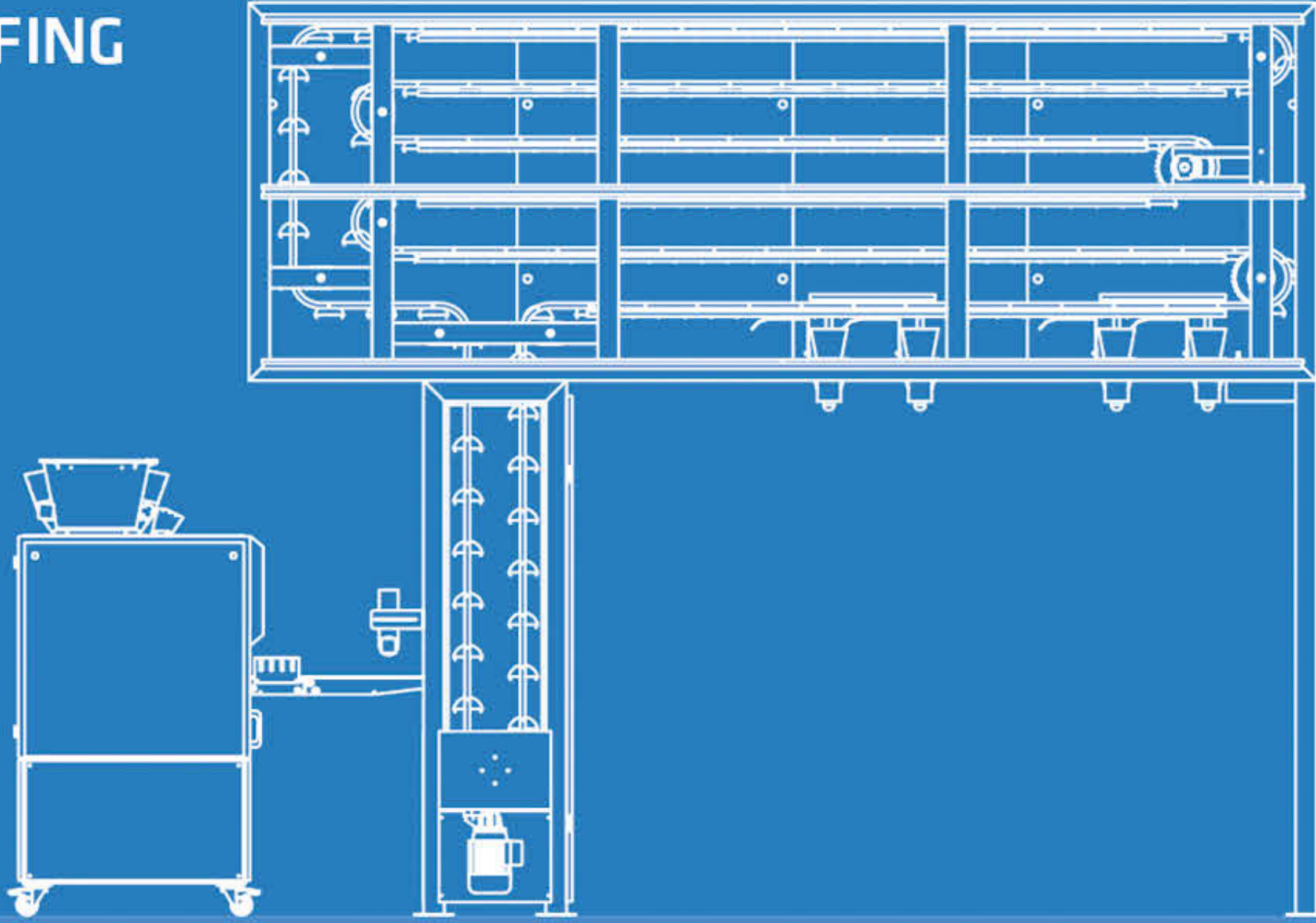

LOADING

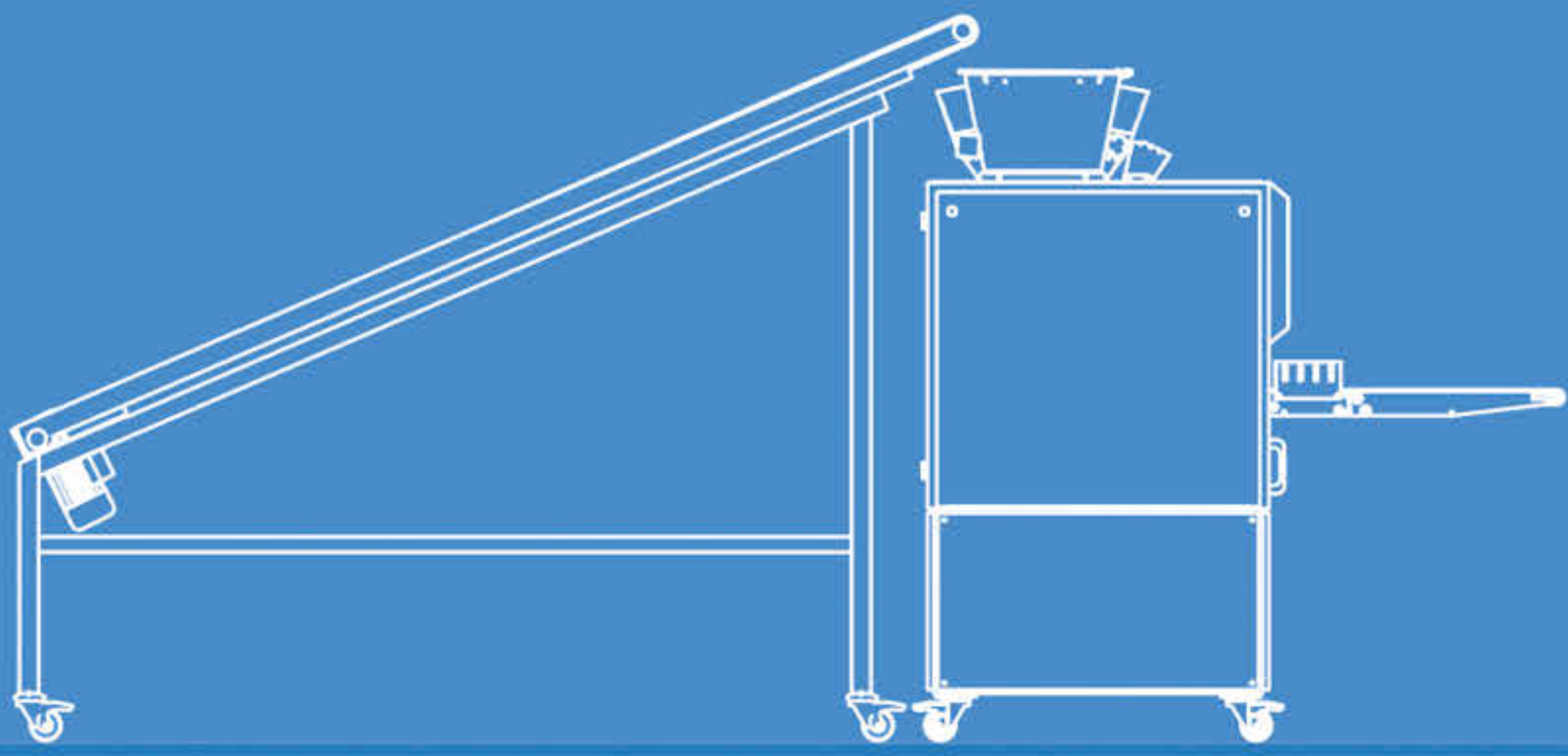

MOULDING

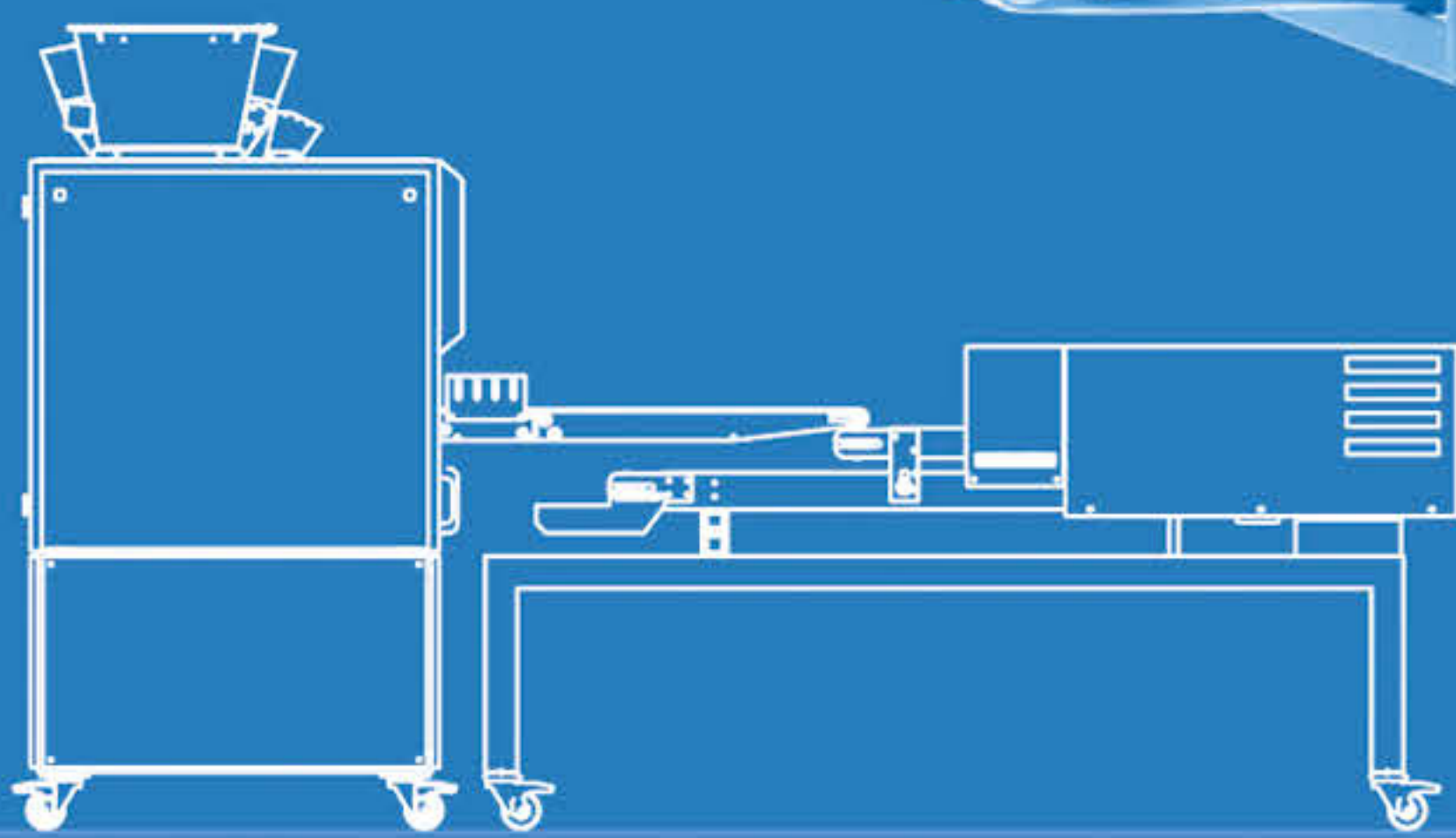

PANNING

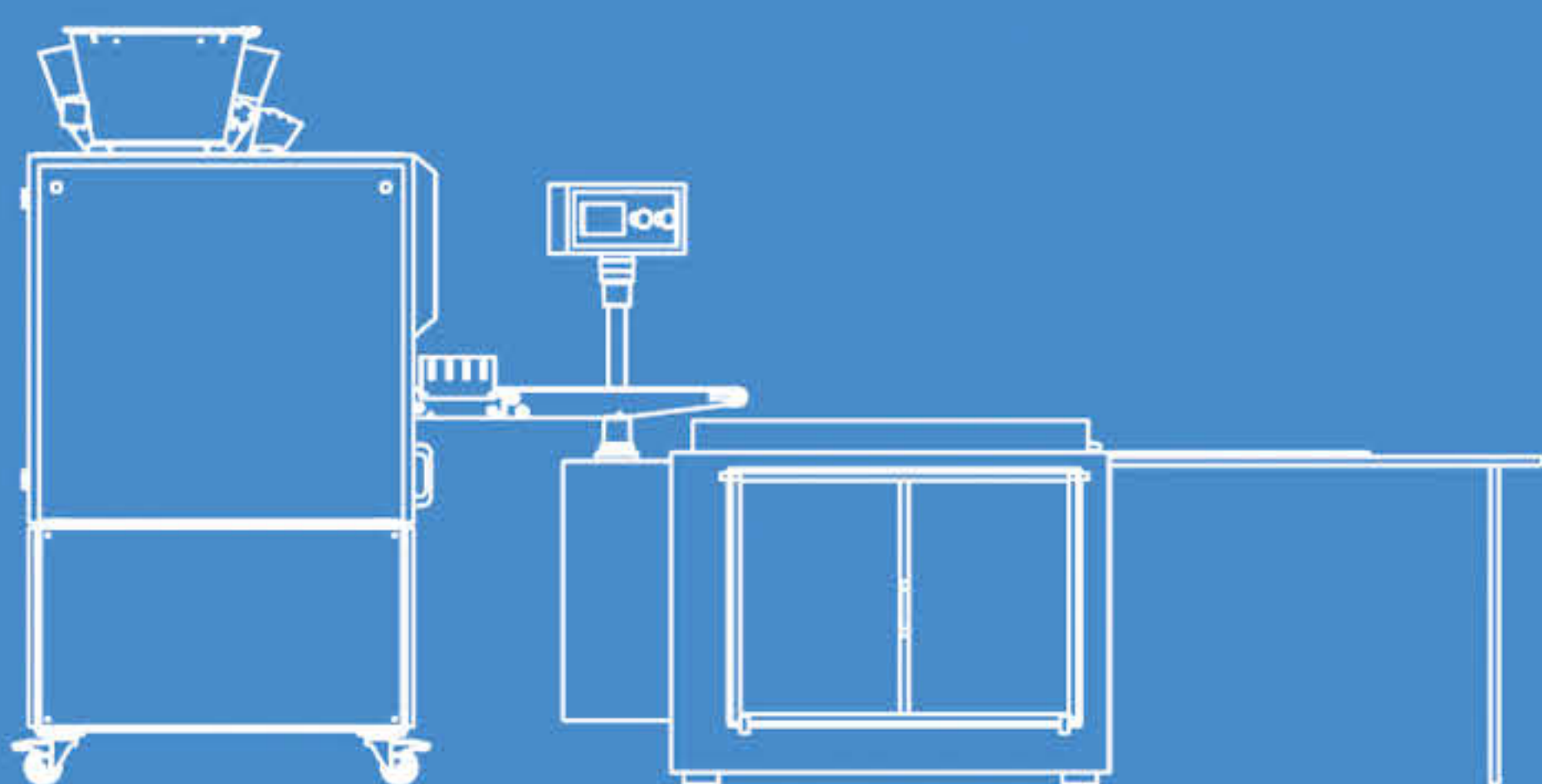

VERSATILITY





EXCLUSIVE DISTRIBUTOR:



Erika Record Baking Equipment
37 Atlantic Way, Clifton, NJ 07012

Phone: 973.614.8500 | Fax: 973.614.8503
E-mail: sales@erikarecord.com | Web: www.erikarecord.com