

TANK - S150

Tank designed to melt and keep chocolate, creams, preserves etc.
Equipped with pump-operated product extractor pump or for automatic feeding to tempering machines using a level sensor (optional). Power supply pipes (optional) to other machines, heated and thermoregulated.
Stirrer continuous rotation or intermittent programmable.

TECHNICAL CHARACTERISTICS:

- Frame and tank made entirely of steel inox 304
- Heating in a water bath controlled by thermos regulator
- Reverse for pipes cleaning
- Removable stirrer and pump for easy cleaning
- Wheels with brake for the handling
- Tank capacity Kg. 150
- Volt 240/400 – Hz 50/60 – Kw 3,3
- Dimensions: mm 900 x 900 x h 1100

OPTIONALS:

- Tube for feeding to other machines
- Heating for feeding tube
- Level sensor



TANK 300 KG

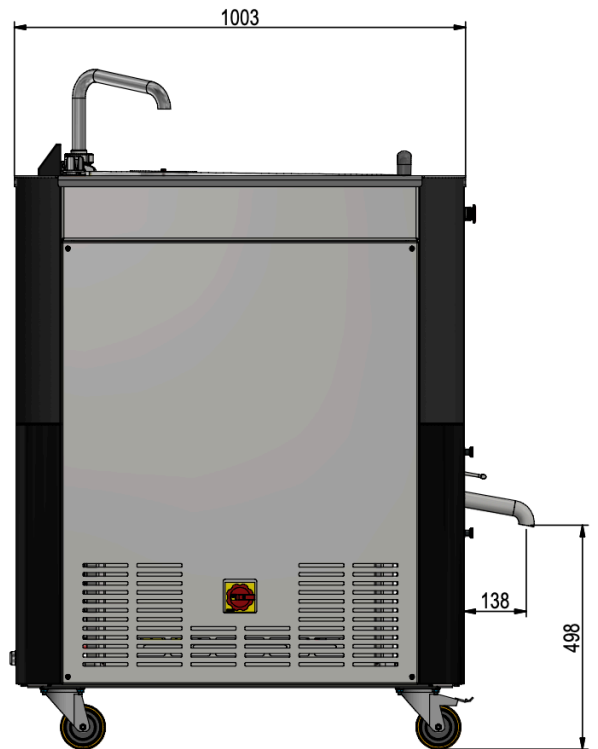
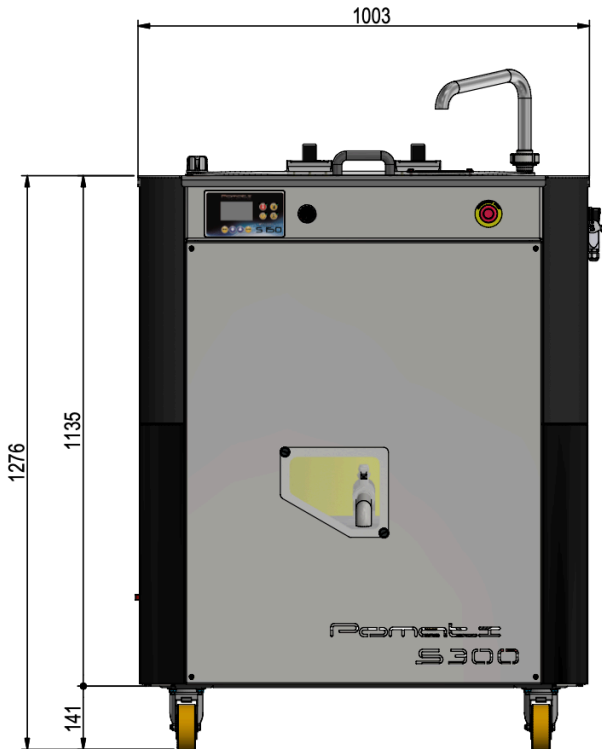
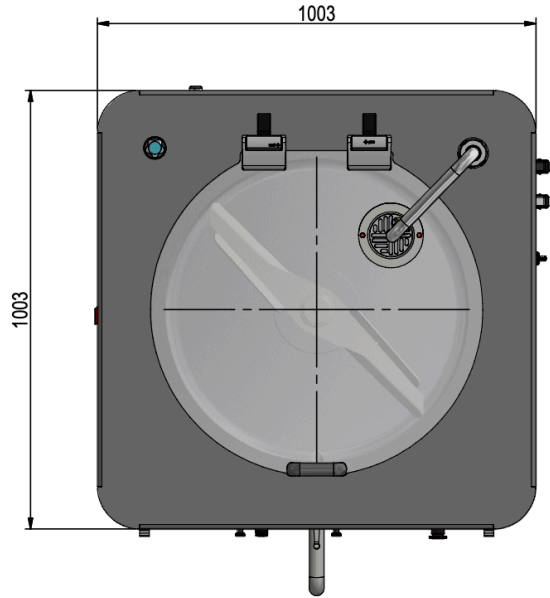



DIMENSIONS: mm 1003X1003X1276



TANK CAPACITY: 300 kg



POWER: 4 KW

Tank designed to melt and keep chocolate, creams, preserves etc. Equipped with pump-operated product extractor pump or for automatic feeding to tempering machines using a level sensor (optional). Power supply pipes (optional) to other machines, heated and thermoregulated. Stirrer continuous rotating or intermittent programmable

TECHNICAL CHARACTERISTICS:

- Frame and tank made entirely of steel inox 304
- Heating in a water bath controlled by thermos regulator
- Reverse for pipes cleaning
- Removable stirrer and pump easy cleaning
- Tank capacity Kg 300
- Volt 240/400 - Hz 50/60 - KW 4

OPTIONAL:

- Tube for feeding to other machines
- Heating for feeding tube
- Level sensor