

## A RELIABLE PLANETARY MIXER AVAILABLE IN 40, 60, AND 80 QUART CAPACITIES

The Z.Matik | Zeus planetary mixer delivers professional-grade performance in a compact, reliable design. Built in Italy with stainless-steel components, it easily handles doughs, creams, and batters with consistent results. The quiet motor, variable-speed controls, and durable transmission ensure smooth operation and long service life. Easy to clean and maintain, the Zeus is ideal for retail bakeries seeking dependable mixing performance and everyday efficiency.



### HOW IT WORKS

- First, add your ingredients into the mixing bowl.
- Next, ensure the proper tools have been attached to the mixing head and select your desired mixing speed.
- Finally, start the mixer and mix until the desired consistency is achieved.

### FEATURES

✓ **Bowl Scraper**  
*Eliminates manual scraping for faster, more consistent mixing.*

✓ **Durable Construction**  
*Built with heavy-duty stainless steel*

✓ **Electromechanical Controls**  
*Simple, reliable interface with timer, variable speed, and emergency stop.*



✓ **Safety Guard**  
*Stainless-steel guard protects operators while maintaining visibility.*

✓ **Tool Kit**  
*Includes paddle, whisk, and spiral attachments for versatile mixing.*



✓ **UL Components**  
*UL-certified parts ensure lasting safety and performance.*

✓ **Variable Speed**  
*Adjustable speeds for precise control of doughs, creams, and batters.*



### AVAILABLE OPTIONS

+ **Additional Bowls**

+ **Additional Tools**

+ **Bowl Reduction Kit**

+ **Bowl Reduction Kit**  
*Enables a larger model mixer to process smaller batches. Kits enables you to transform an 80 quart to 60 quart, 60 quart to 40 quart, and 40 quart to 20 quart bowl sizes.*

+ **Bowl Trolley**  
*Easily move the mixing bowl across the production floor.*



+ **Digital Controls**  
*Programmable, digital touchpad with automatic bowl lift included.*



**TECHNICAL SPECIFICATIONS**

	ZEUS 40	ZEUS 60	ZEUS 80
<b>ELECTRICAL SPECIFICATIONS</b>	220V   60 Hz   3ph		
<b>MOTOR SPECIFICATIONS</b>	2.2 kW   3 HP	2.9 kW   4 HP	4 kW   5.5 HP
<b>BOWL CAPACITY</b>	40 quart	60 quart	80 quart
<b>BOWL DIMENSIONS</b>	15.75"   400 mm	17.75"   450 mm	19"   480 mm
<b>STANDARD DIMENSIONS (L x W x H)</b>	39.76 x 31.89 x 59.65"   1010 x 810 x 1515 mm		
<b>NET WEIGHT</b>	629 lb.   285 kg	640 lb.   290 kg	651 lb.   295 kg
<b>SHIPPING DIMENSIONS (L x W x H)</b>	34.47 x 49.21 x 66.92"   85 x 125 x 170 cm		
<b>SHIPPING WEIGHT</b>	695 lb.   315 kg	706 lb.   320 kg	717 lb.   325 kg

Notes:

---

---

---

---

---

---

---

---

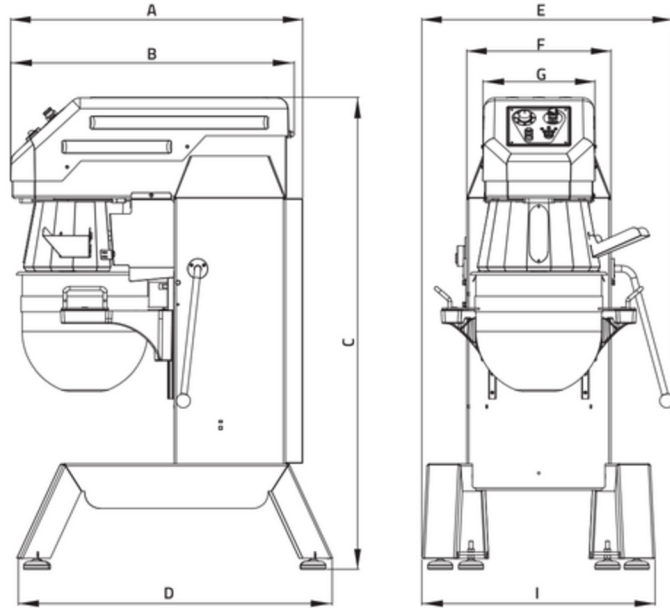

**ACCESS OUR  
PRODUCT PAGE & VIDEO**



*Specifications are subject to change without notice, as we remain committed to delivering the best equipment possible. Technical specifications and warranty information will be provided in your quote.*